

The Citation Fourteen

Professional FM/Stereo FM Tuner
with Dolby NR

harman / kardon

Instruction Manual

TABLE OF CONTENTS

	PAGE		PAGE
Introduction	2	Description of Controls	8
Outstanding Features	2	Power Switch	8
Warranty Policy	3	Gain Controls (L & R)	8
Unpacking	3	Function Switch	8
Service	3	Stereo Indicator	8
Installation	4	Stereo Threshold Control	8
Power Requirements	4	Dolby Switch	9
AC Convenience Receptacle	4	Stereo Noise Filter Switch	10
Fuse	4	Mute Switch	10
Antenna	4	Muting Threshold Control	10
Choice of Transmission Line	5	Level Set Tone Switch	10
Grounding the Antenna	5	Dial Scale	10
Output Connections	5	Tuning Meter	10
Variable Output (L & R)	5	Quieting Meter	11
Fixed Output	8	Antenna Orientation	11
To Scope (X & Y)	8	Multipath	11
To Quad Decoder	8	Tuning Weak Stations	11
Tape Out	8	Tuning Mechanism	11

LIST OF ILLUSTRATIONS

	PAGE
Rear Panel	6
Front Panel	7
Quieting Meter	11

INTRODUCTION

Your new Citation Fourteen tuner is part of a family of high fidelity equipment deliberately designed to effect breakthroughs in the quality of sound available in your home. The Citation Fourteen tuner has created new standards against which all other tuners will be measured.

Starting with the most advanced concepts in electronic technology, . . . Harman-Kardon engineers developed new instrumentation and new features. The introduction of the Citation Fourteen is significant, for us . . . and for you.

SOME OF THE FEATURES YOU ARE ABOUT TO ENJOY ARE:

- A revolutionary **QUIETING METER** (patent pending) that measures the signal-to-noise ratio of the incoming signal.
- Optimum phase linearity in the RF and IF sections, providing an audio signal virtually free from IM, THD and phase distortion that continues the Citation tradition of "straight wire with gain". Multiplex phase-locked loop circuits that sense and quantify phase error in incoming pilot signals and automatically make corrections.
- Dolby B noise reduction system that spectacularly improves the quality of reception of Dolbyized FM and stereo FM broadcasts. Spurious disturbances such as co-channel, multipath and SCA interference are sharply reduced; such broadcasts are received with almost startling freedom from background noise. Not only does the Dolby system improve the ultimate signal-to-noise ratio, but, in effect, the **power of the incoming signal picked up by your antenna is almost doubled.**

PLUS THESE OUTSTANDING FEATURES:

- **5 SECTION GANG FM FRONT END.** Suppression is more than 100 dB eliminating all spurious responses.
- **IF FILTER** with sealed 9 pole phase linear LC network combines excellent phase linearity with outstanding alternate channel rejection.
- **IF STRIP** with 2 extremely high gain ICs provides extraordinary hard limiting of noise.
- **RATIO DETECTOR** of unique design ensures precision linearity and exceedingly low distortion.
- **SPECIAL WIDEBAND CIRCUITRY** permits feeding the composite signal into external, discrete, 4 channel stereo adapter without loss of phase linearity or amplitude.
- **400 CYCLE CALIBRATION REFERENCE TONE** adjusted in amplitude, equivalent to 50% modulation, facilitates level setting of reel-to-reel or cassette tape recorders.
- **CENTER TUNING METER** augments quieting meter for lowest distortion point.
- **THREE POSITION FM STEREO NOISE FILTER** eliminates background noise from weak signals.

WARRANTY POLICY

We warrant each factory wired tuner to be free from defects in material and workmanship under normal use and service, and in accordance with the conditions set forth below. Should a defect occur within the period specified, and, providing the unit is returned to either HARMAN-KARDON or an authorized HARMAN-KARDON warranty station, transportation prepaid, and which our examination shall disclose to our satisfaction to be defective, we will, for a period of two (2) years from date of original purchase, either replace or repair and install any defective parts free of charge.

To obtain service under the terms of this policy, it is necessary for you to retain your ORIGINAL BILL OF SALE.

In the event your equipment requires service during the warranty period, only presentation of your original bill of sale to either a factory-authorized repair agency or the factory, itself, will insure your rights under the policy, as outlined in this manual.

The Citation warranty does not include packaging or transportation charges to and from the factory or authorized warranty repair station.

This warranty is not applicable to any unit which shall have been repaired or altered in any way so as, in our judgment, to affect its reliability or stability or general performance or has been subject to neglect, misuse, abuse, negligence or accident; or which has had the serial number altered, effaced or removed. Neither shall this warranty apply to any instrument which has been connected other than in accordance with instructions furnished by us.

This warranty is in lieu of all other warranties, expressed or implied, and of all other obligations or liabilities on our part, and we neither assume nor authorize any representative or other person to assume for us any other liability in connection with the sale of this instrument.

UNPACKING

After unpacking the Citation Fourteen, inspect it carefully for signs of transit damage. The tuner was subjected to numerous quality control tests and inspections prior to packing and should therefore be in perfect operating condition. If damage is visible, notify your dealer at once. If the tuner was shipped to you, notify the transportation company without delay. HARMAN-KARDON will cooperate with you in such instances, but only YOU can recover from the carrier for damage incurred during shipment.

SERVICE

HARMAN-KARDON has a special customer service division to answer all questions pertinent to the installation and operation of your unit. Please feel free to write to us at any time for prompt and complete advice.

If your problem cannot be resolved through our combined efforts, we may refer you to a local authorized repair agency or authorize the return of your unit to the factory. To aid us in selecting a service station convenient to you, it would be helpful if you would indicate the major city closest to your home.

Please address your inquiry to:

Customer Service Department
HARMAN-KARDON, INC.
Plainview, New York 11803

Be sure to include the model and serial number of your unit.

In the event it must be returned, an authorization form and proper packing instructions will be forwarded to you. This authorization form MUST BE RETURNED with your unit.

UNDER NO CIRCUMSTANCES SHOULD YOUR UNIT BE SHIPPED TO THE FACTORY WITHOUT PRIOR AUTHORIZATION.

INSTALLATION

The Citation Fourteen produces very little heat and may be installed without regard to normal ventilation requirements. However, if you are installing the unit in custom cabinetry, it is recommended that you avoid placing the tuner directly over heat producing units such as a basic amplifier or tube-type preamplifier. (A handsome walnut enclosure or custom cabinet is available from your dealer as optional equipment.)

POWER REQUIREMENTS

The AC line cord plug may be inserted into any outlet furnishing 117 volts, 50/60 Hz AC current. (Voltage may vary between 105 and 125 volts.)

For use in areas which provide 210 to 250 volts AC, 50/60 Hz current, the Citation Fourteen may be rewired as shown on the schematic diagram in the Technical Manual. However, rewiring should be done only by an authorized technician.

Unless otherwise indicated, all Citation Fourteen tuners have been factory wired to operate at a nominal voltage of 117 volts AC.

AC CONVENIENCE RECEPTACLE

An AC convenience receptacle is provided on the rear panel of your Citation Fourteen. Any equipment connected to this receptacle will be controlled by the on/off switch of the tuner. It is therefore recommended that this receptacle be used for tuner associated accessories such as an antenna rotator, antenna booster, quad decoder, etc.

FUSE

The Citation Fourteen is protected by a STANDARD FAST BLOW fuse located on the rear panel. If this fuse is blown, it is to be replaced only with one of the SAME TYPE and SAME RATING.

It is important to note that replacing the FAST BLOW FUSE with a slow blow type or with a fuse of higher rating, WILL PREVENT MAXIMUM PROTECTION of the tuner and could result in severe damage. Such damage will not be covered by the Factory Warranty.

VOLTAGE (50/60 Hz)	FUSE TYPE	FUSE RATING
105-125 VAC	3AG or AGC	1.5 Amperes
210-250 VAC	3AG or AGC	1.0 Amperes

ANTENNA

In selecting an antenna system for use with your Citation Fourteen, please keep in mind that your tuner's full potential and performance capability can only be achieved when you provide the best possible signal to the antenna terminals.

If you live in a metropolitan area (or if you wish to receive signals from many directions) an ordinary crossed dipole, conical or three element in-line antenna should serve adequately. The three or four element in-line (uni-directional) type is the most satisfactory of the group, but due to its high directivity, it becomes necessary to include an antenna rotator to change the direction of the antenna for best reception.

For near-fringe and fringe reception, a six-to-eight-element log-periodic or Yagi is recommended. Both types are excellent and offer superior front-to-back ratio, (ratio of forward pickup to that at the rear, greater gain and rejection of noise. Both types are highly directional and require a rotator. Far fringe reception requires an antenna with eight or ten elements. This type antenna is usually quite heavy and requires extra support and bracing when installed.

Remember, FM stereo reception requires greater gain than standard monophonic FM. It is therefore, advisable to purchase the antenna which can "pull in" a station with the greatest gain and lowest possible noise.

Are there high-rise buildings in your area? Water towers? Gas tanks? Mountains? They can all cause serious reception problems by reflecting FM signals which, when received, will result in audible distortion. This form of distortion is known as multipath interference and is similar to "ghosts" on your TV set.

Multipath interference can be reduced or eliminated by purchasing a highly directional antenna with a rotator. Proper orientation of the antenna may tune out multipath completely, or alternate it below audibility.

If installed properly, an outside antenna will reject unwanted signals, local noise, multipath interference, and provide greater signal strength than any elementary type. Increased signal strength usually results in the reception of additional stations with amazing clarity.

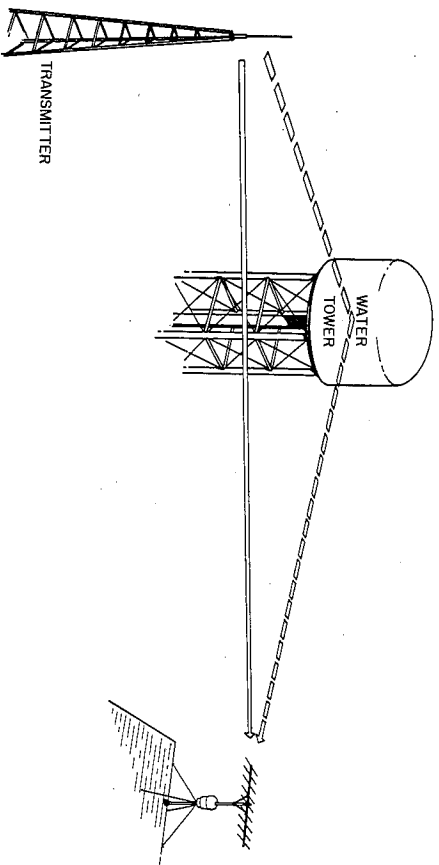

CHOICE OF TRANSMISSION LINE

The major types of antenna lead-in wire available are flat ribbon, tubular, foam, coaxial and encapsulated. Each type has specific advantages which must be weighed against the costs involved in each installation.

A high-quality 100-mil, 20-gauge, polyethylene 300-ohm twin-lead is usually satisfactory for most installations. Tubular or foam line provides better protection than flat ribbon against the elements and industrial smog. Coaxial lead-in is useful for multiple-set installations and to reduce pick-up of extraneous noise. Coaxial line has a higher-loss characteristic than twin-lead (tubular or foam), but the loss is constant, and can easily be compensated for through the use of a more powerful antenna.

The encapsulated 300-ohm line (also referred to as 300-ohm shielded lead) has excellent weather-resistant characteristics and a somewhat lower loss factor than coaxial.

To avoid signal loss, the transmission line should be kept as short as possible and, preferably, should run vertically down to the set.

When using an external antenna with 300 ohm twin lead, connect both leads to the two 300 ohm antenna terminals on the rear of your tuner. If your external antenna is connected with 75 ohm coaxial cable, use the coaxial 75Ω connector adjacent to the antenna terminal, or connect between the 75 ohm and GND terminal, with the outer conductor or shield of the cable connected to the GND terminal.

GROUNDING THE ANTENNA

An antenna can act like a lightning rod because it is often the highest metal structure on the roof. It must therefore be grounded. Attach a heavy-gauge aluminum wire to the mast and a lightning arrestor to the transmission line where it enters the building.

On apartment-roof installations, a lightning arrestor may be attached to the mast, and another to the transmission line where it enters the building. In general, it is always advisable to keep the lightning arrestor outside the home interior. Where ground rods are used, they should be at least four feet long and deeply sunk into the ground.

When selecting an FM antenna system remember the following:

1. The proper antenna should be used for a given location. The further you are located from the FM transmitter, the more gain the antenna must offer.
2. The antenna should have uniform signal level across the entire frequency range it covers.
3. Antenna placement is extremely important for maximum signal reception.
4. The installation must be rigid to avoid damage to the roof, chimney, wall or other property.
5. Careful routing of the lead-in line to avoid pick up of local interference. A poorly routed lead-in line (which touches metal portions of the house, etc.) will reduce signal strength by a significant margin.

OUTPUT CONNECTIONS

The Citation Fourteen provides five different output receptacles, each designed for a specific function. One receptacle (Tape Out) is located on the front panel and uses a standard $\frac{1}{4}$ " phone jack. The other four, are located on the rear panel. All receptacles accept standard RCA phono jacks. In making your installation, you may use one or more pair, depending on your requirements.

VARIABLE OUTPUT (L&R)

These receptacles may be connected either to the preamplifier or directly to the basic amplifier. In either case, the level of signal at these receptacles is controlled by the GAIN CONTROLS on the front panel of your tuner. These Gain Controls may be used when adjusting the level of your tuner to match the level of other source material connected to your system, such as phonograph, tape recorder, etc.

FRONT PANEL

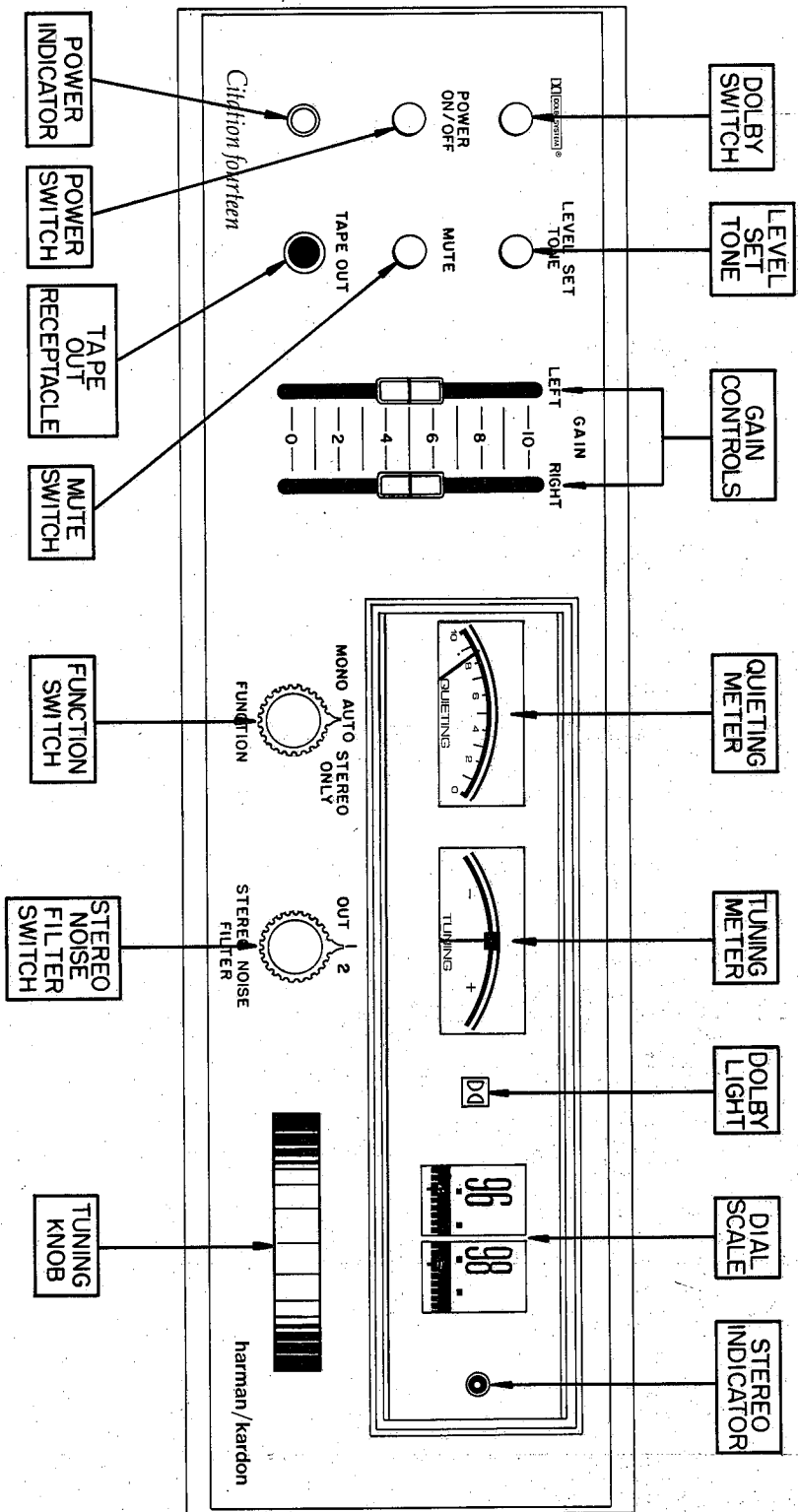

REAR PANEL

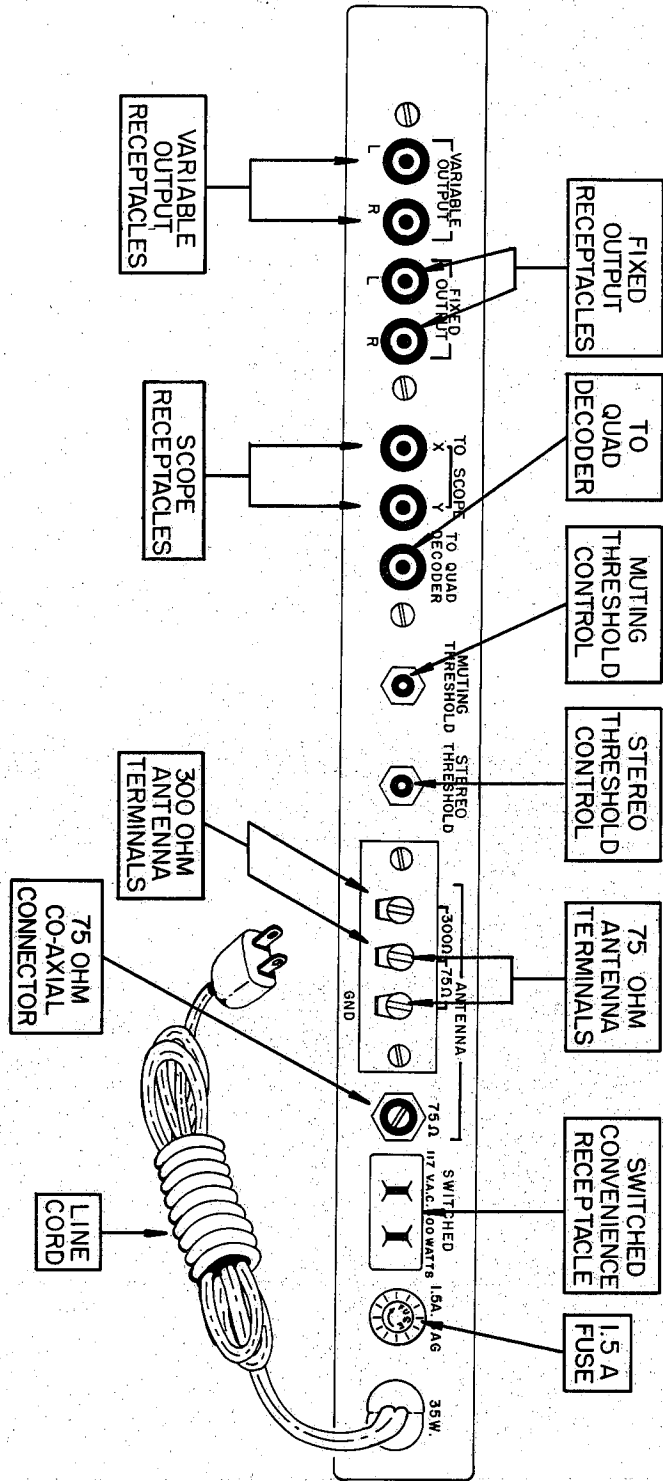

FIXED OUTPUT (L&R)

These receptacles provide the full output of your tuner and are NOT controlled by the GAIN CONTROLS. They should be connected to either your preamplifier or to a tape recorder. They should NEVER be connected directly to a basic amplifier.

TO SCOPE (X&Y)

These are identical to the FIXED OUTPUT receptacles and are provided for those who wish to visually monitor the output of the tuner using an oscilloscope, or other electronic test equipment. If desired they may be used as a second pair of FIXED OUTPUTS.

TO QUAD DECODER

The Citation Fourteen anticipates the further development and standardization of four channel FM broadcasting. The tuner provides an output receptacle to connect FM four channel signals to a decoding device suitable for any anticipated quadriphonic broadcast system.

TAPE OUT

The front panel receptacle is identical to the FIXED OUTPUT located on the rear panel. It has been located on the front panel as well to provide instant accessibility for temporary connection to a tape recorder.

DESCRIPTION OF CONTROLS

Each control and tuning indicator of the Citation Fourteen has been designed to perform a specific useful function — either individually or in combination with others. In order to obtain the best possible performance from your tuner, we suggest that you read the following so that you may take advantage of the full potential of these controls and indicators.

POWER SWITCH

This switch provides AC power to the tuner and to the AC convenience receptacle on the rear panel. When in the "ON" position, the pilot light jewel below the switch and the meter and dial scale windows will be illuminated.

GAIN CONTROLS (Left & Right)

These control the output level of the tuner at the VARIABLE OUTPUT receptacles on the rear panel. If the tuner is used in conjunction with a basic amplifier only, these controls will adjust the system gain. When connected to a preamplifier, these controls may be pre-set to match the level of other signal sources connected to your system. The volume control of your preamplifier may then be used as the master gain control of your system.

FUNCTION SWITCH

The three position FUNCTION SWITCH is used to select the desired mode of operation of your tuner.

1. MONO — This position bypasses ALL stereophonic circuitry of the tuner and reproduces ALL stations monophonically.
2. AUTO — In this position, your tuner utilizes a stereo sensing circuit which will automatically determine whether your tuner is receiving monophonic or stereophonic broadcasts. The tuner automatically adjusts to the mode of operation. When the tuner is reproducing stereophonically, the STEREO INDICATOR will be illuminated.
3. STEREO ONLY — In this position, the tuner will reproduce stereophonic broadcasts only. Monophonic signals will be completely muted, as well as stereo stations below threshold.

STEREO INDICATOR

The "Stereo Indicator" light indicates when the Citation Fourteen is reproducing stereo FM broadcasts.

STEREO THRESHOLD CONTROL

This rear panel control can be adjusted to determine the number of stereo stations the tuner will reproduce in the AUTO and STEREO ONLY positions of the Function Switch.

In the full counter-clockwise position, the automatic switching circuits have maximum sensitivity and all stereo stations within the range of the tuner will be reproduced. However, due to weak signals (or their distance from your antenna) some stations will contain noise levels which degrade performance when reproduced in stereo.

In order to reproduce these stations monophonically (when in the AUTO position of the Function Switch), or to eliminate them completely (when in the STEREO ONLY position of the Function Switch), rotate the STEREO THRESHOLD control clockwise until only good quality stereo stations are reproduced.

DOLBY SWITCH

Despite the fact that FM is the highest quality transmission system yet devised, there is some degradation of the signal-to-noise ratio in this method of broadcasting. Stereo FM can, at times, compound this deficiency. The solution to this problem requires that ALL elements of the transmission chain — from transmitter to receiver — be of the highest quality.

The Citation Fourteen includes a Dolby noise reduction system which spectacularly improves the received quality of FM or stereo FM broadcasts.

This system requires the insertion of a Dolby encoder at the transmitter before the signal is pre-emphasized. With the Dolby switch in

the "IN" position, the encoded signal is decoded. (A Dolby light will be illuminated when the switch in "IN".)

Listening to a decoded Dolby broadcast may present the illusion of a loss of high frequencies. Actually, what you are hearing is the Dolby decoder de-emphasizing the signal which was pre-emphasized before transmission.

The method of recording a Dolby processed signal is directly related to whether or not your recorder also incorporates a Dolby noise reduction system. The following chart indicates all possible conditions and should be used as a guide in making recordings.

Type of Broadcast	Method of Transmission	How Reproduced by Cit-14	Position of Dolby Switch on Cit-14	Non-Dolby Tape Recorder		Dolby Switch on Dolby Tape Recorder	
				Record	Playback	Record	Playback
NON DOLBY	Mono	Mono	OUT	Normal	Normal		
			OUT	Normal	Normal	IN	IN
			OUT	Normal	Normal	IN	IN
	Stereo	Stereo	OUT	Normal	Normal		
			OUT	Normal	Normal	IN	IN
			OUT	Normal	Normal	IN	IN
DOLBY	Stereo	Stereo	OUT	Normal	Normal		
			OUT	Normal	Normal	OUT	IN
			OUT	Normal	Normal	OUT	IN
	Mono	Mono	OUT	Normal	Normal		
			OUT	Normal	Normal	OUT	IN
			OUT	Normal	Normal	OUT	IN
Stereo	Stereo	Mono	*	Normal	Normal	*	*
			*	Normal	Normal	*	*

*When listening to a stereo broadcast in MONO position, the 19KHz stereo pilot signal will defeat the Dolby decoding process, effectively placing the Dolby switch in the out position.

STEREO NOISE FILTER SWITCH

Stereophonic FM broadcasts require greater signal strength at the antenna terminals (as compared to monophonic FM broadcasts). Weak or distant stereo signals will naturally contain more noise than a monophonic signal of similar strength. The Citation Fourteen STEREO NOISE FILTER will reduce or eliminate this undesirable noise. In the "OUT" position, the switch has no effect. Filtering is provided in the "1" position and reaches maximum in the "2" position.

MUTE SWITCH

The MUTE circuit reduces the audible noise (hissing or rushing sound) found between stations.

To eliminate interstation noise, push the MUTE Switch "IN". To defeat the circuit, push the switch again. It will return to the "OUT" position.

MUTING THRESHOLD CONTROL

This rear panel control adjusts the level at which muting action will take place. Minimum muting action occurs in the full counter-clockwise position. Maximum muting is achieved in the full clockwise position.

The full clockwise position will also eliminate stations with poor transmission quality. The control should be adjusted to the point where you receive only those stations which meet your standards of broadcast quality.

LEVEL SET TONE SWITCH

The LEVEL SET TONE switch on the front panel activates a generator which produces a sine wave test tone of 400 Hz at a level equivalent to 50% of full modulation of an FM signal.

"Off-the-air" tape recordings can be made with complete assurance of correct levels by using the test tone as a recording level reference. After activating the LEVEL SET TONE adjust the record level controls of your tape recorder so the record level meters or other indicators on your tape recorder register a level of "0" VU. At this setting recordings can be made with optimum signal-to-noise ratio and the distribution of dynamic level changes in music will be properly captured.

Recorders vary in the saturation and overload characteristics of their record amplifiers which affect the occurrence of distortion in the recording process. You may find with your recorder that with the

"0" VU setting of the record indicators, the reference tone is too high. While signal-to-noise ratio is usually optimum at the "0" VU setting, signal vs. distortion typically improves at lower recording levels (down to -8 VU). With some experience you will find a recording level within these values that provides a combination of high signal-to-noise ratio and low distortion that is right for you and your recorder. Because of the variation of levels required by different tape recorders, it is advisable to experiment with the record level controls on your recorder. However, once this level is determined it can remain constant.

DIAL SCALE

The DIAL SCALE consists of a large drum which rotates in conjunction with the knurled flywheel. The DIAL SCALE is calibrated with an FM frequency scale (88-108 MHz) and a logging scale (0-10).

Most FM stations operate at frequencies which are not whole numbers (such as 96.3 MHz) as compared to 96 MHz. Ideally, each megacycle division on the frequency scale should be divided into 10 parts to enable the user to pinpoint the location of the station. This would require a dial scale which would be impractical.

The logging scale which is divided into 100 equal parts provides a means of finding your favorite station, once you have noted its position on the logging scale. For example, in New York City, WQXR operates at 96.3 MHz. After locating this station through the use of the frequency scale (between 96 and 98 MHz) the pointer may fall on 42 on the logging scale. Make a note of this setting. For future tuning to WQXR simply set the pointer to 42 on the logging scale.

TUNING METER

All FM broadcast stations are assigned a frequency by the Federal Communications Commission. The signals from these stations extend equally above (+) and below (-) the assigned frequency. The frequency spectrum is called the "pass band".

The tuning meter of the Citation Fourteen (when centered) is tuned to the exact center of the pass band. However, you may be detuned slightly (either + or -) and still not experience degradation of the quality of sound by remaining within the limits of the pass band. Only when detuned enough to reach the edge of the pass band will the signal become noisy, distorted and finally disappear.

It is important to note that it is NOT ALWAYS NECESSARY to be tuned to the EXACT center of an assigned pass band to obtain clean, undistorted sound.

QUIETING METER

"Quieting" is a term used in the measurement of the relative signal to noise ratio of a broadcast signal.

Conventional signal strength or center channel meters do not indicate the quality of the received signal — simply their strength and pass band accuracy. Harman-Kardon's extraordinary QUIETING METER actually indicates or "reads" the signal-to-noise ratio or the QUALITY of the received signal.

Maximum deflection of this meter (highest number) represents the best listening point within the pass band EVEN IF THE TUNING METER IS NOT AT THE CENTER OF THE PASS BAND.

As you detune closer to the edge of a station's pass band, the QUIETING METER will immediately reflect the increased noise and distortion.

The QUIETING METER will "ALWAYS" agree with what you hear and will "ALWAYS" indicate the best tuning point.

The preceding paragraphs provide a basic and concise description of the function and operation of the controls and indicators of the Citation Fourteen. They have been described under what are considered "normal" operating conditions.

However, abnormal conditions sometimes do occur and could pose some special problems.

The following material deals with some key problems which could arise under "abnormal" conditions and the methods which can be employed to solve them.

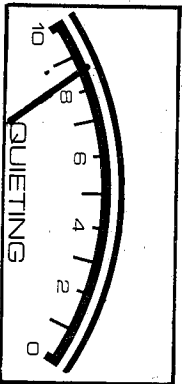

ANTENNA ORIENTATION

If your antenna system uses a rotation device, the best antenna orientation will be achieved when the QUIETING METER indicates the greatest steady deflection (highest number). Rotate the antenna in the general direction of the transmitting station's antenna and consult the QUIETING METER to make fine adjustments of the antenna's position.

MULTIPATH

"Multipath" is a form of audible distortion caused when a signal and its echoes reach a receiver a fraction of a second apart. (Similar to "ghosts" on your TV screen). Such distortion can be caused by high rise buildings, airplanes, water towers, mountains, etc. Conventional signal strength tuning meters are unable to provide guidance to reduce such interference.

However, since multipath signals always increase background noise, the QUIETING METER may be used to tune both the Citation Fourteen and your antenna to eliminate or drastically reduce multipath interference.

TUNING WEAK STATIONS

When using the MUTTE function of the Citation Fourteen, most stations received will be relatively strong and have good signal-to-noise ratio.

However, when a "weaker" station is immediately adjacent to a "stronger" station, it may be difficult to tune in the weaker station with clarity. In such situations, the stronger station may mix with or mask the weaker station even though the tuning meter indicates that you are precisely tuned to the weaker station. Under such circumstances, you can achieve the best possible signal quality from the weaker station by using the QUIETING METER to tune away from the stronger station while remaining within the pass band of the weaker station.

TUNING MECHANISM

The Citation Fourteen does not employ a conventional tuning knob. Instead, a solid, knurled flywheel is mounted horizontally for precise, smooth and accurate tuning. The flywheel is carefully designed for easy access and for extraordinarily smooth and efficient changing of stations.

Citation 14

HARMAN-KARDON INCORPORATED
55 AMES COURT, PLAINVIEW, N.Y. 11803